

EIC SOLUTIONS, INC.



AIR CONDITIONER INSTALLATION
AND OPERATION MANUAL

FOR 200 BTU MODEL #'S

AAC-120-4XT
AAC-120-4XT-HC
AAC-120-4XT-F
AAC-120-4XT-HCF
AAC-120-4XT-XXXXXX

***QUALITY ENCLOSURES AND COOLING
SOLUTIONS FOR EVERY ENVIRONMENT***

TABLE OF CONTENTS

1. GENERAL INFORMATION	
PRINCIPLES OF OPERATION.....	3
2. INSTALLATION	
2.1 CHOOSING A LOCATION.....	4
2.2 ORIENTATION.....	4
2.3 PREPARING THE ENCLOSURE.....	6
2.4 INSTALLING THE AIR CONDITIONER.....	6
INSTALL A THROUGH MOUNT AIR CONDITIONER.....	6
INSTALL A FLUSH MOUNT AIR CONDITIONER.....	7
INSTALL THE DRAIN LINE.....	7
APPLY POWER.....	10
3. OPERATION	
THERMOSTAT SET POINTS AND HEATING COOLING UNITS.....	11
MAINTENANCE.....	11

EIC SOLUTIONS INC.
1825 STOUT DRIVE
WARMINSTER, PA 18974
PHONE 1-215-443-5190 OR 1-800-497-4524
FAX 215-443-9564
EMAIL INFO@EICSOLUTIONSINC.COM

VISIT US ON THE WEB AT WWW.EICSOLUTIONSINC.COM.

CONTACTS:
SALES MANAGER – BRUCE BLACKWAY
ENGINEERING MANAGER – AL GILLEN
ENGINEERING - JOHN KWIATKOWSKI
OPERATIONS MANAGER – DAVID BATES
OFFICE MANAGER – MYRA HODGDON

1. GENERAL INFORMATION

1.1 PRINCIPLES OF OPERATION

In 1834 Jean Peltier discovered that by passing a current through two dissimilar conductors the junction of those materials will either absorb or release heat depending on the direction of the current flow. Thirteen years earlier, Thomas Seebeck had discovered that current would flow when you placed a temperature gradient across the junction of two dissimilar metals. These two discoveries were the basis of thermoelectrics. With the advent of modern semiconductors, thermoelectric devices became practical for real world applications and are now found in everything from consumer goods to spacecraft.

Your EIC Solutions Thermoelectric Air Conditioner operates on this same principle so there is no compressor and no expensive, ozone depleting CFC's. EIC's air conditioners use Thermoelectric "modules" sandwiched between high performance aluminum heat sinks, high CFM axial fans, and a patented electronic design to "pump" the heat from the inside of your enclosure to the outside, without exposing your delicate electronics to any outside air or contaminants. See Figure 1.1.

EIC uses only the highest quality components in our air conditioners and you can expect years of trouble free cooling from these solid-state devices. Every unit we sell is backed by our one year parts and labor warranty.

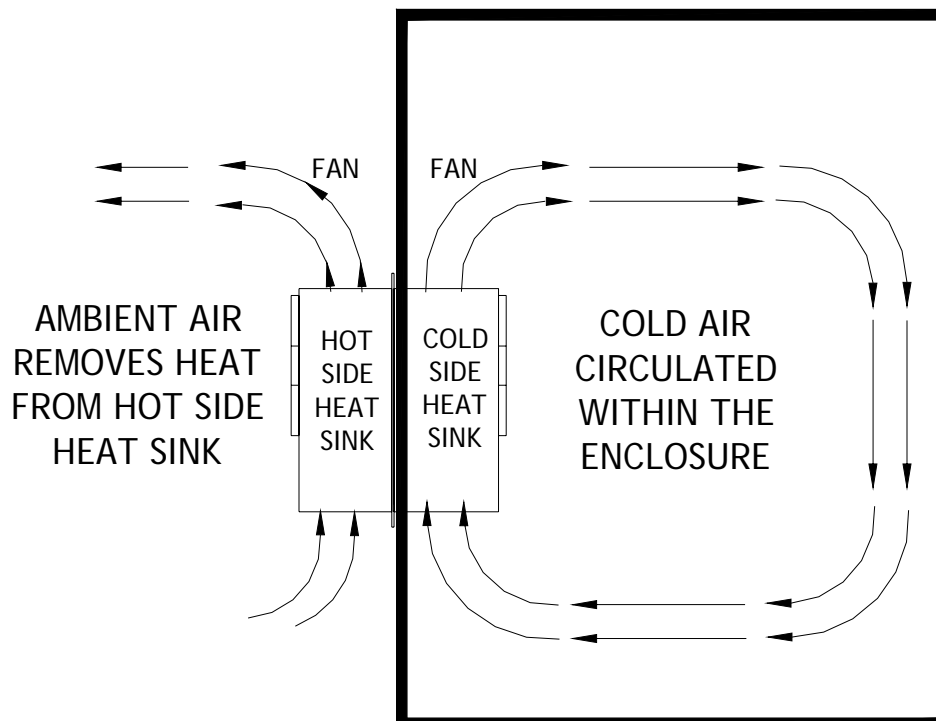

FIGURE 1.1

2. INSTALLATION

2.1 CHOOSING A LOCATION ON YOUR ENCLOSURE

When choosing a mounting location for your unit, be sure to keep airflow of both the interior and exterior heatsinks and fans in mind. Adequate clearance between the fans/heatsinks and nearby surfaces is required for unrestricted airflow which will ensure optimal performance and long, trouble free operation. The general rule is to allow a minimum of two inches between the fans or heatsinks and any surface. Refer to the air flow diagram in figure 1.1.

Other considerations in deciding on a mounting location include but are not limited to; allowing access to the thermostat (this will be inside the enclosure) if frequent adjustments are to be made, allowing access to the hot side heat sinks (this will be on the outside of the enclosure) for cleaning if the unit will be used in a dirty environment and positioning the unit so that the hot side (outside) is not in an aisle or other area where it might be damaged.

2.2 ORIENTATION

Your AC unit was designed to be mounted vertically on the front, rear, or side of your enclosure. This AC unit should never be mounted horizontally on the top or bottom of your enclosure. Mounting the AC on the top of your enclosure can result in damage to your equipment from dripping condensate. If mounted on the bottom of your enclosure, any condensate that is produced will not be able to drain from the integral drip pan. This may lead to fungal growth and/or early failure of the AC unit.

Vertically mounted 200 Btu units are always mounted with the fans at the top. (Fig. 2.1) In this orientation any condensate that is produced will be collected in the integral Condensate Drip Pan and directed outside the enclosure via the drain tube.

Mounting the unit with the fins in a horizontal position will cause condensate to drip in an uncontrolled manner, possibly damaging electronic equipment within the enclosure. If this orientation is the only possible configuration, contact the Engineering Dept. at EIC for a custom solution.

Never mount the 200 Btu unit horizontally on top of an enclosure. Doing so can result in damage to your equipment from dripping condensate.

There are two mounting styles of our 200 Btu thermoelectric cooler and each has its own mounting template and gasket.

One mounting style is the through mount design in which a portion of the unit extends inside the enclosure. (Fig. 2.1)

The other style is the flush mount design, in which all of the unit is outside of the enclosure. (Fig. 2.2) The last character in the flush mount model number will always be "F", as in AAC-120-4XT-F and AAC-120-4XT-HCF.

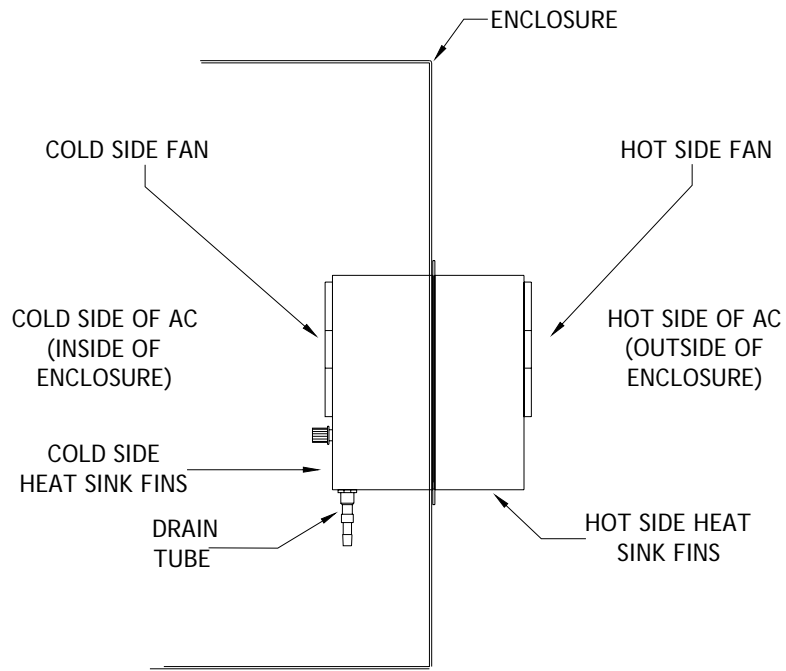

VERTICAL INSTALLATION OF AN
AAC-120-4XT, 200 BTU UNIT
WITH INTEGRAL DRIP PAN

FIGURE 2.1

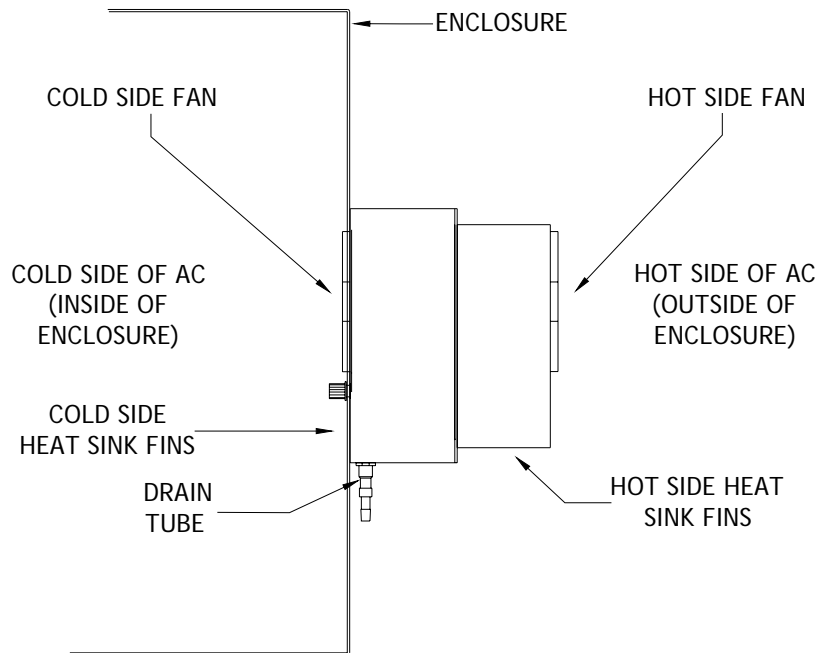

VERTICAL INSTALLATION OF AAC-120-4XT-F,
200 BTU FLUSH MOUNT UNIT WITH
INTERGRAL DRIP PAN

FIGURE 2.2

2.3 PREPARING THE ENCLOSURE

To mount the 200 Btu unit you will need to cut an opening in your enclosure and drill mounting holes. A cut out drawing showing the cut out size and hole locations has been included in this manual (see Fig. 2.3 & 2.4). You also received a cut out stencil with your air conditioner. The instructions for installing the air conditioner are printed below.

TOOLS AND MATERIALS NEEDED:

- AAC-120-4XT-xxx cut out stencil
- Center Punch
- Tape Measure and pencil
- Jigsaw or suitable alternative
- Electric drill
- # 29 drill bit (.136") and a # 8-32 tap and tap handle (for Through Mount units)
- # 16 drill bit (for Flush Mount units)
- Ten # 8-32 x 3/8" stainless machine screws (supplied)
- Ten nylon washers (supplied)
- One neoprene gasket (supplied)

CUT THE OPENING AND DRILL MOUNTING HOLES IN THE ENCLOSURE

1. Using the guidelines provided in the installation manual, choose an appropriate location for the air conditioner on your enclosure.
2. Tape the supplied cut out stencil to the enclosure in the location you have chosen.
3. Before marking, cutting or drilling, check that the location meets the clearance requirements as specified in the installation manual.
4. Using a pencil, center punch, or other method, mark the exact center point of each mounting hole on the enclosure. Also mark the four corners of the section to be cut out.
5. Remove the stencil and using a pencil or other method, connect the marks you made at the corners of the cut out, forming a rectangle.
6. Using the jigsaw, cut the opening in the enclosure.

FOR A THROUGH MOUNT UNIT

1. Using the # 29 drill bit, drill a hole at each of the mounting hole marks you made earlier.
2. Using the 8-32 tap, tap each of the holes you have drilled.

FOR A FLUSH MOUNT UNIT

1. Using the # 16 drill bit, drill a mounting hole at each of the mounting hole marks you made earlier.

2.4 INSTALLING THE AIR CONDITIONER

INSTALL A THROUGH MOUNT AIR CONDITIONER

1. Lay the air conditioner down with the cold side fan (side with the thermostat) facing up.
2. Take the supplied gasket and lay it down on the flange.
3. Take one of the supplied mounting screws and, from the under side of the flange, push it up through the top right mounting hole, and through the hole in the gasket. The gasket hole is undersized and will hold the screw in place. Repeat this for the top left mounting hole.

4. Set the AC unit in the hole you've cut in the enclosure, and using a screwdriver, carefully start the two screws you attached to the gasket to the tapped holes in the enclosure. Do not tighten these at this time.
5. Install the rest of the screws in the flange placing a nylon washer on each fastener and screw them into the tapped holes in the enclosure. Do not tighten them completely.
6. Remove the two starter screws and place a nylon washer on each and reinstall.
7. Tighten all screws.

INSTALL A FLUSH MOUNT AIR CONDITIONER

1. Insert one of the mounting screws through one of the top corner mounting holes you've drilled in the enclosure, from the inside of the enclosure. While holding this screw in place, push the gasket onto the protruding end of the screw on the outside of the enclosure. Follow this same procedure until the three top and three bottom screws are in place and through the appropriate holes in the gasket.
2. Place a Phillips screwdriver in one of the top corner mounting screws in the enclosure. Carefully align the AC unit mounting hole with screw being held. Bring the AC in contact with the screw and start the screw into the mounting hole in the AC unit. Only engage a few threads.
3. Follow step 2 above for the remaining top mounting screws and then for the bottom screws. Do not tighten any of the screws.
4. Install the remaining screws and tighten evenly.

INSTALL THE DRAIN LINE

Two hose fittings (right angle and a straight one) and a length of PVC tubing are provided with your air conditioner.

1. Choose one of the fittings and install it on the bottom of the AC unit.
2. Attach the supplied PVC drain tube to the hose fitting.
3. If you are installing a Through mount AC unit (Fig. 2.1), this tube should be routed to the bottom of the enclosure and fed through a 3/8" hole to the outside.
4. If you are installing Flush mount AC unit (Fig. 2.2) the drain line is already on the outside of the enclosure and should be routed so that any dripping condensate does not create a safety hazard.

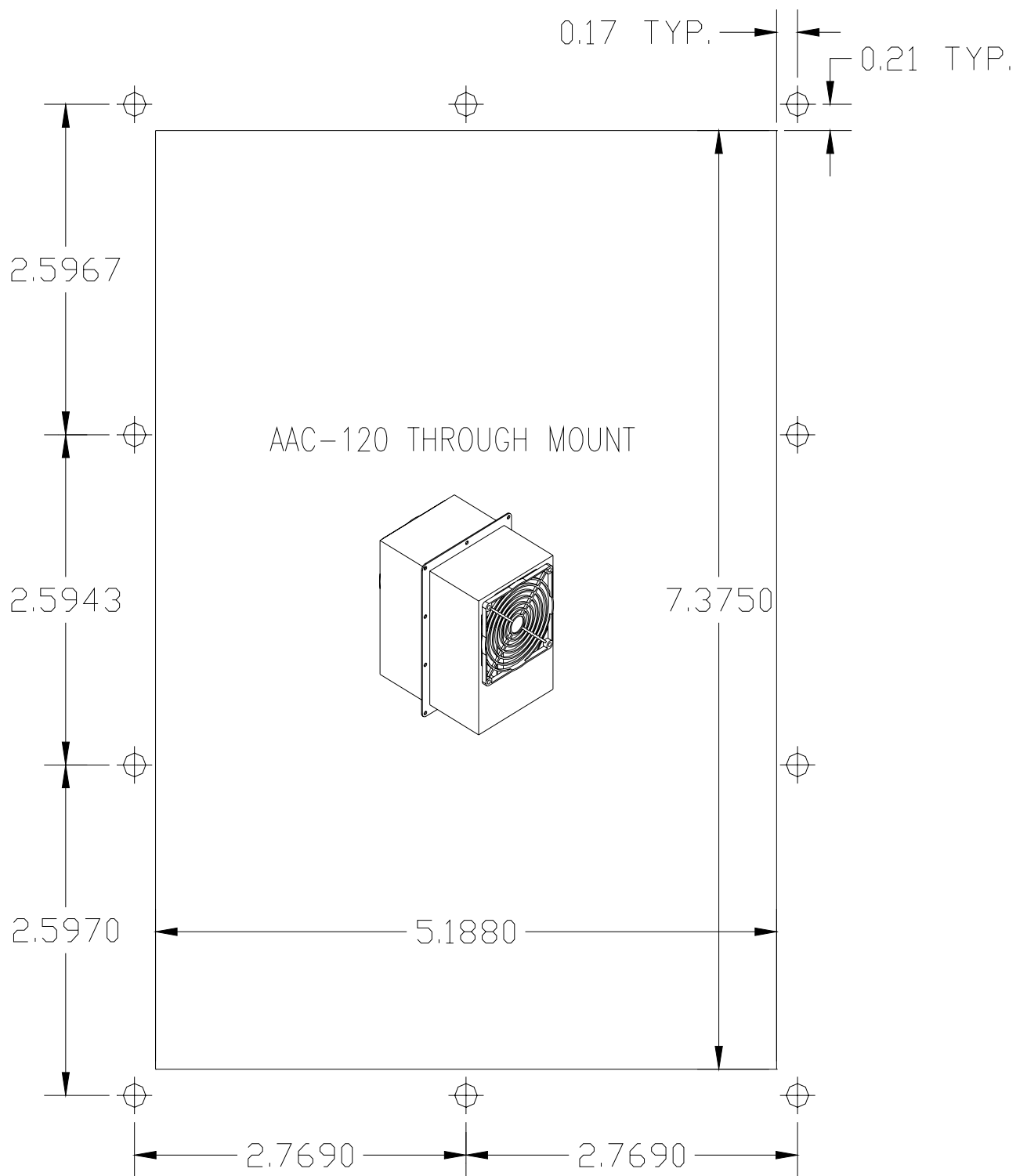

FIG. 2.3

(not to scale)

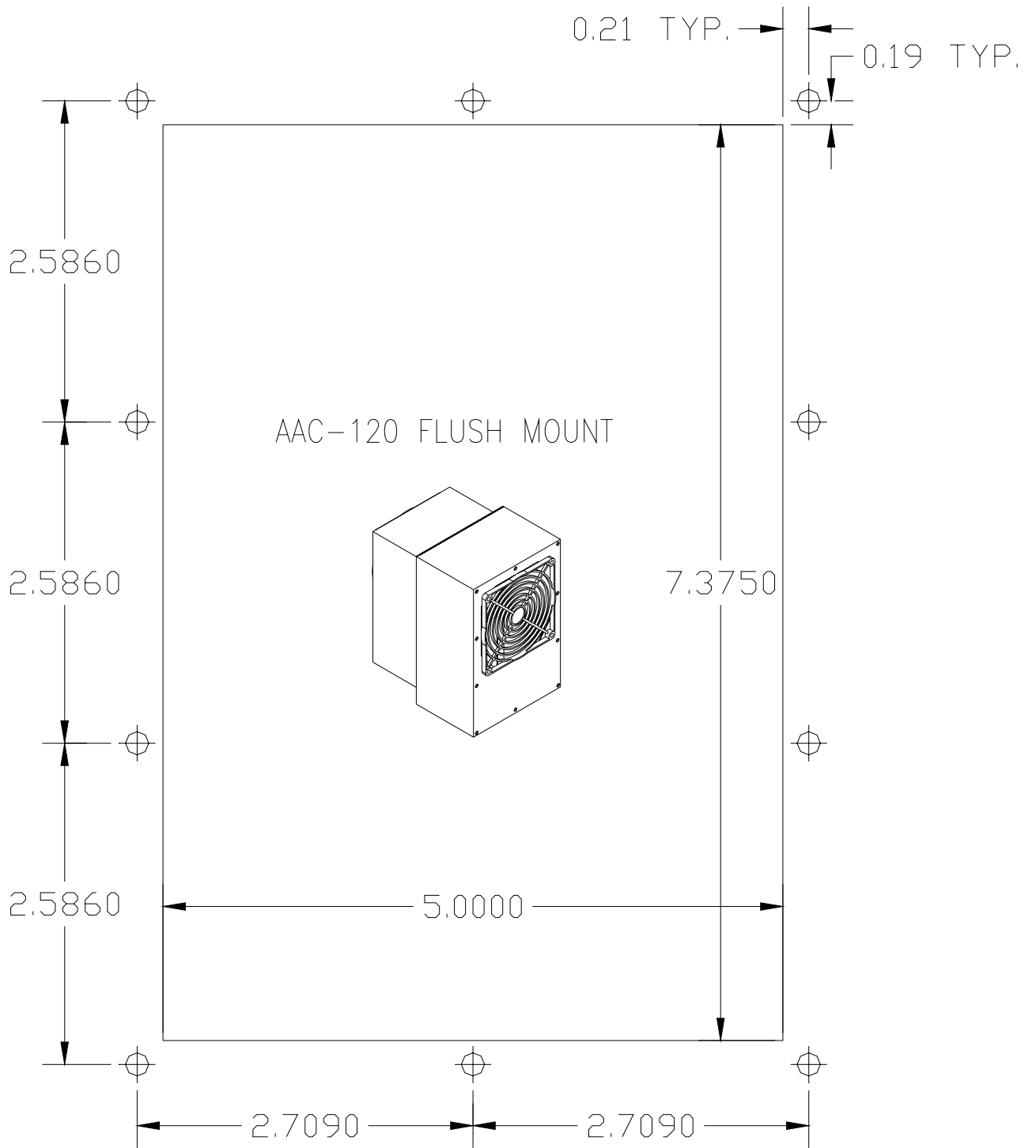

FIG. 2.4

(not to scale)

APPLY POWER

Your 200 Btu AC unit operates on 24 volts DC and can be purchased with or without a DC power supply. This power supply is not waterproof or designed for exposure to the elements and should always be installed in a dry, protected location, preferably inside the enclosure.

120/240 VAC Supply Voltage

If you purchased the 120 or 240 VAC unit you received the DC power supply with your unit. To apply power to the AC unit, plug the DC jack from the power supply into the front of the AC. Once the adapter is connected to the AC unit, apply power to the DC power supply as follows:

120 VAC - plug cord into standard 120 volt grounded outlet.

240 VAC units - the cord will not have a plug on the end. Connect the wires to an appropriate power source using standard safe wiring methods as follows:

For US installations wire colors are as follows:

Black - line
White - line/neutral
Green - ground

For European installations the wire colors are as follows:

Brown - line
Blue - line/neutral
Green/yellow - ground

Amperage for 120 VAC unit is 1.75 amps
Amperage for 220 VAC unit is 1.0 amps

DC Supply Voltage

If you purchased our DC model, you will have received a 3 wire shielded cable with a DC jack on one end and no termination on the other. This cable should be connected to an appropriate 24-28 volt DC power supply as follows:

Red - positive
Black - negative
Green - ground

Amperage for a 24 VDC unit is 3.75

For other voltages you will receive a separate wiring diagram showing the correct method of applying power.

If you purchased a Digital Temperature Controller with your AC unit, a separate wiring diagram has been provided which will show the correct method of applying power to your particular air conditioner.

Upon applying power to the air conditioner the fan on the cold side (inside the enclosure) will come on. The hot side fan (outside the enclosure) may also run depending on where the thermostat is set. The cold side fan always runs to circulate air within your enclosure thereby eliminating any "hot spots". The hot side fans will only run when the air conditioner is cooling - they are "pumping" the heat from the inside of your enclosure to the outside air.

3. OPERATION

3.1 THERMOSTAT SET POINTS AND HEATING/COOLING UNITS

SETTING THE THERMOSTAT

Your EIC air conditioner is equipped with an adjustable thermostat. The set point you choose should be based on the desired internal temperature of the enclosure. The air conditioner will run until the set point temperature is achieved within the enclosure and then the hot side fans and the thermoelectric cooling modules will shut down. The cold side fan will continue to run, circulating the air to maintain a uniform temperature within the enclosure.

HEATING AND COOLING UNITS

If you purchased an HC unit (heating and cooling), the heater operation is controlled by a fixed-point thermostat. This thermostat is set to turn the heaters on when the temperature within the enclosure falls to approximately 45° F and turn the heaters off when the temperature rises to approximately 55° F.

The cooling operation is controlled by the adjustable thermostat just as it is with a cooling only unit. To avoid having the heating and cooling on at the same time, do not set the cooling thermostat below 65° F.

3.2 MAINTENANCE

MAINTENANCE

EIC Thermoelectric Air Conditioners are virtually maintenance-free. The only time maintenance is required is when a unit is installed in an extremely dirty environment. In these cases, the hot side heat sinks (outside the enclosure) should be inspected regularly for a build-up of dust or dirt. If a build-up is present on the heat sink fins, it can be easily removed as follows:

1. Disconnect the power from the unit.
2. Dry dust/dirt can be removed using compressed air to blow out the heat sinks. Do not direct any high-pressure air at the fans.
3. Your AAC-120-4XT-xxx air conditioner is appropriate for NEMA 4X installations and is designed to allow for water wash down of the hot side of the unit, which is outside of the enclosure **(never the cold side, which is inside the enclosure)**. A pressure washer can be used to carefully clean the hot side heat sink fins when compressed air will not provide adequate cleaning. Never direct high-pressure water at the fans. Never direct high-pressure water at the joint formed by the mounting flange, gasket and enclosure. Never allow the cold side of your unit to get wet

Keeping the hot side heat sink fins free from any insulating build-up of dirt or dust will ensure long, trouble-free operation of your air conditioner.

ONLY NEMA 4X UNITS, WITH MODEL NUMBERS CONTAINING "4XT", ARE DESIGNED FOR THE HOT SIDE OF THE AIR CONDITIONER (OUTSIDE THE ENCLOSURE) TO TOLERATE EXPOSURE TO WATER. NEVER EXPOSE THE COLD SIDE OF THE AIR CONDITIONER (INSIDE THE ENCLOSURE) TO WATER.

If you have any questions about any aspect of your EIC air conditioner, don't hesitate to call us at our toll-free number listed below or at 215-443-5190.